

UB-E4/8 Oven / Proofer

Project \_\_\_\_\_

Item \_\_\_\_\_

Quantity \_\_\_\_\_



**SIZE:**

UB-E4/8 - 73- 1/2" High, 30- 1/8" Wide, 36" Deep  
1867 mm High, 765 mm Wide, 914 mm Deep

NU-VU's UB-E4/8 oven/proofer features our patented V-AIR ◦ System in the oven. The heat is distributed evenly throughout the oven cavity by the fan located in the top of the oven which blows the air down the inside walls of the cavity and up and out through the holes at each shelf. This gives your product an even bake, top to bottom, side to side and front to back without ever turning pans.

The proofer portion of the UB-E4/8 comes standard with a manual fill humidity system.

The UB-E4/8 has a capacity of 4 full size or 8 half size pans in the oven and 8 full size or 16 half size pans in the proofer.

These units also feature flush mount doors, which means no sagging or leaking. Lift off hinges allow for easy cleaning. The lighted oven and proofer compartments make it easy for you to do sight baking and proofing without having to open the doors, disturbing the internal temperatures.

**CONSTRUCTION:**

- Welded stainless steel
- Fully insulated
- Control panel accessible through front and top of unit
- Heating elements accessible inside of cabinet and through top

**CONTROLS:**

- Solid state controls
- Indicator lights for thermostats
- Microswitch fan motor cut-off

**LABORATORY CERTIFICATION AND APPROVAL**



**STANDARD FEATURES:**

- V-AIR ◦ technology
- Stainless steel construction
- Magnetic door latches
- Heavy duty casters
- Tempered glass doors
- Silicone rubber door gaskets
- Flush mount, lift off, no sag doors
- Stainless steel hinges
- Overflow drain and pan
- Separate heat and humidity controls for proofer
- Manual fill proofer

**OPTIONAL FEATURES:**

- Internal steam
- AutoMist humidity in proofer
- Warmer in proofer
- Cook'n Hold
- Solid door(s)
- Product probe
- Two speed fan

NU-VU ◦ UB-E4/8 Oven/Proofer



NU-VU ◦ Food Service Systems

www.nu-vu.com  
5600 13th Street  
Menominee, MI 49858

1-800-338-9886 Toll Free  
1-906-863-4401 Phone  
1-906-863-5889 Fax

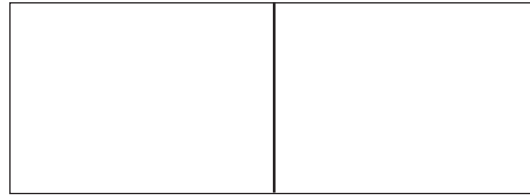

Approval / Stamp

## UB-E4/8 Oven / Proofer

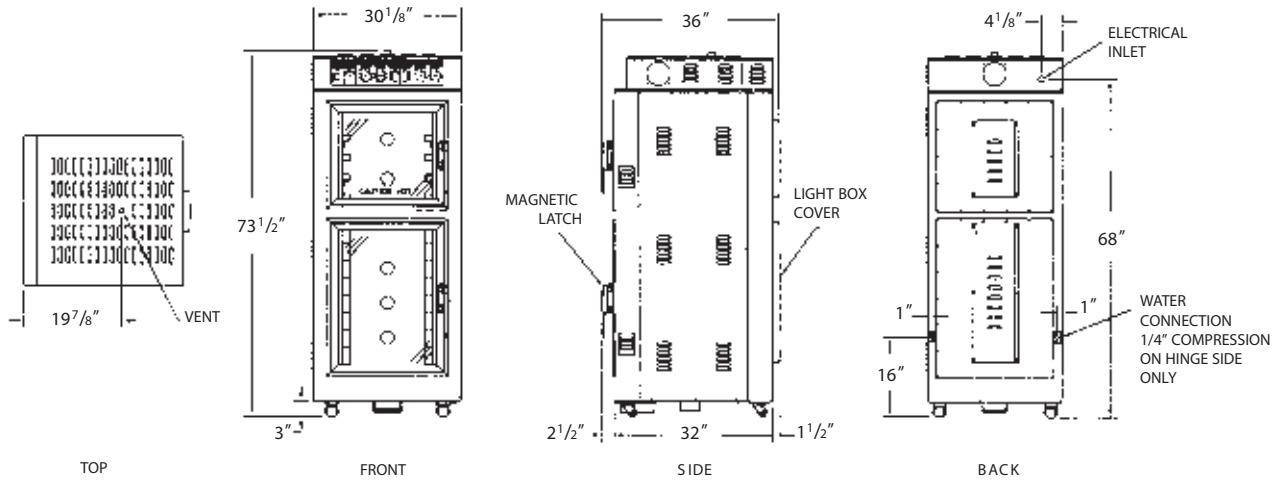

NU-VU <sup>®</sup> UB-E4/8 Oven/Proofer

**SPECIFICATIONS:**

**ELECTRICAL:**

208 or 240 Volt single or three phase is standard. (Specify at time of order.)

**SERVICE CONNECTIONS:**

UB-E4/8 is shipped from factory to be hard wired on site. Single phase uses two wire system. Three phase uses three wire system.

**ELECTRICAL:**

Amp Draw	208/1	208/3	240/1	240/3
	39	27	36	24

**WATER:**

A 1/4" waterline is required if a steam or AutoMist option is selected. A water filtration system should be used to minimize mineral build-up.

**LISTINGS:**

The UB-E4/8 has NSF & C-ETL-US listings.



**INSTALLATION:**

Allow four inches on each side and back of unit for ventilation of oven.

**CAPACITY: Per Compartment**

	18"x26" Sheet Pans	13"x18" Sheet Pans	Spacing
Oven	4	8	4"
Proofer	8	16	3- 1/2"

**DIMENSIONS:**

	Height	Width	Depth
Exterior	73- 1/2"	30- 1/8"	36"
Interior			
Oven	18- 1/4"	18- 1/4"	28- 1/2"
Proofer	30- 1/4"	18- 1/2"	28- 1/2"

**DOOR SWING:** Oven - 24- 1/4" (641 mm)  
Proofer - 24- 1/4" (641 mm)

**PACKING SIZE:**

86" High, 36" Wide, 38" Deep  
(2184 mm High, 914 mm Wide, 965 mm Deep)

**SHIPPING WEIGHT:**

550 Pounds (250 Kg), FOB Menominee, MI 49858