

SMOKE6 Half-Size Oven/Smoker with Humidity



Shown with Optional Casters

SIZE:

SMOKE6 - 48-3/8" High, 27-3/8" Wide, 36" Deep
1229 mm High, 696 mm Wide, 915 mm Deep

The smoker ovens offers the capability to dry bake, bake with moisture, warm, slo-cook, hold and smoke. A minimum footprint is required because of the top mounted motor.

The heat, moisture and smoke are distributed evenly throughout the oven cavity by the fan located in the top of the oven. Since each control is independent, a variety of different conditions may be utilized in processing products. The use of all controls will produce a warm, tender, moist product.

CONSTRUCTION:

- Stainless steel construction
- Fully insulated
- Control panel provides access from front of unit and through top
- Heating elements accessible inside and top of unit

CONTROLS:

- Solid state controls
- Indicator light for thermostat
- Cook'n Hold feature utilizes cook thermostat, hold thermostat and 24 hour timer
- Smoke on/off switch
- Separate heat and humidity controls

STANDARD FEATURES:

- Stainless steel construction
- 6" stainless steel legs
- AutoMist humidity system
- Cook'n Hold
- Variable moisture control
- Includes 5 chrome racks
- Stainless steel door

OPTIONAL FEATURES:

- Casters
- Additional chrome racks
- Stainless steel cart or stand with or without pan slides
- External smoke box
- Ball valve control for vent

SMOKE6 Half-Size Oven/Smoker with Humidity

LABORATORY CERTIFICATION AND APPROVAL



NU-VU® Food Service Systems

www.nu-vu.com
5600 13th Street
Menominee, MI 49858

1-800-338-9886 Toll Free
1-906-863-4401 Phone
1-906-863-5889 Fax

SMOKE6 Half-Size Oven/Smoker with Humidity

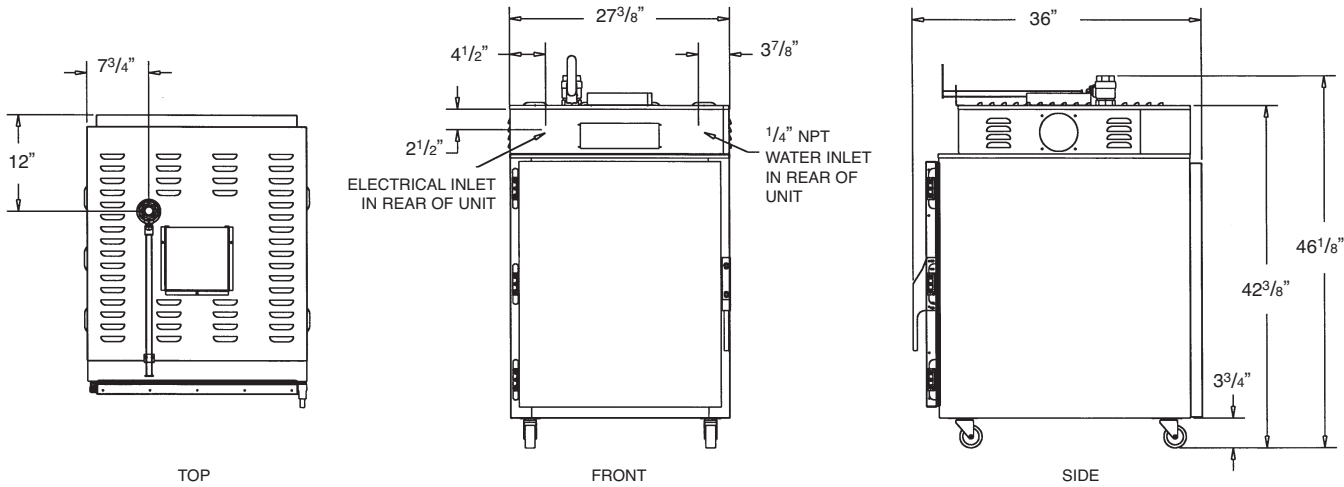
SMOKE6 Half-Size Oven/Smoker with Humidity

SPECIFICATIONS:
ELECTRICAL:

208 or 240 Volt single or three phase is standard.
(Please specify at time of order.)

SERVICE CONNECTIONS:

SMOKE6 is shipped from factory to be hard wired on site.
Single phase uses three wire system. Three phase uses four wire system.

DOOR SWING: Smoker - 27⁵/₈"

PACKING SIZE:

49" High, 36" Wide, 40" Deep
(1245 mm High, 915 mm Wide, 1016 mm Deep)

SHIPPING WEIGHT:

400 Pounds, FOB Menominee, MI 49858

WATER:

A 1/4" waterline is required. A water filtration system should be used to minimize mineral build-up.

LISTINGS:
INSTALLATION:

Allow four inches on each side and back for ventilation of unit.

DIMENSIONS:

	Height	Width	Depth
Exterior	48 ⁻³ / ₈ "	27 ⁻³ / ₈ "	36"
Interior	26"	18 ⁻³ / ₄ "	29"

CAPACITY:

	18"x26" Sheet Pans	13"x18" Sheet Pans	Spacing
Smoker	5	10	3-1/2"

5 Chrome racks

Approximately 150 pounds of product

ELECTRICAL:

	208/1	208/3	240/1	240/3
With internal smoke box	13.5	10	12	8.5
With external smoke box	16	10	14	9

NU-VU® Food Service Systems

www.nu-vu.com
5600 13th Street
Menominee, MI 49858

1-800-338-9886 Toll Free
1-906-863-4401 Phone
1-906-863-5889 Fax